

ROLLARAMP®



TODCO®



ROLLARAMP® DELIVERS SUPERIOR PERFORMANCE, MILE AFTER MILE.

TODCO's commitment to continually improving trucking technology doesn't stop at the back door. In fact, just building the toughest doors wasn't enough for our engineers. So now we build the toughest walk ramps, too.

Just take a look at Rollaramp's new interlocking design system and you'll see what we're talking about. Because by sliding the tread plank sections together before the sides are welded on, and then skip-welding the connections, we've dramatically increased Rollaramp's strength and stability.

And since making multiple deliveries on a daily basis is such hard work, we've also developed a patented spring assist option for Rollaramp that enables the ramp to be lifted to bed height effortlessly, dramatically decreasing driver fatigue.

Rollaramp is available in a variety of standard sizes, from eight to 16 feet, with capacities up to 2,000 pounds. Of course, we can also make custom size ramps to fit individual needs. Plus, with two different skid-resistant surfaces to choose from, in addition to two ramp nose designs, we have a Rollaramp to meet all of your specific delivery needs.



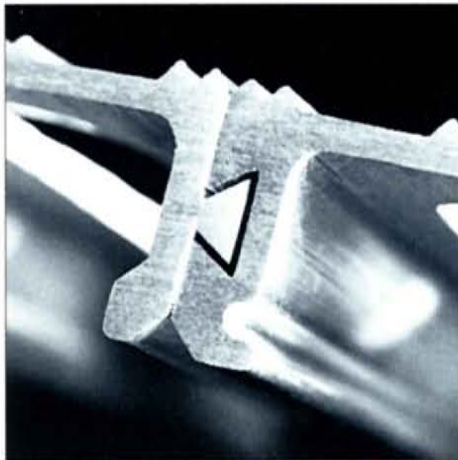

▲ **TODCO's interlock system adds strength along length of the ramp.** Tread plank sections are slid and locked together *before* sides are welded on. Skip-welding of sections then dramatically increases Rollaramp's strength and stability.



▲ **Optional spring assist makes lifting Rollaramp even easier.** Our patented spring assist mechanism enables the ramp to be lifted to bed height effortlessly. Available on new installations and as retrofit for TODCO Rollaramps and other ramps.

▲ **Two ramp surfaces to choose from.** Rollaramp offers a choice of skid-resistant surfaces to make walking, loading and unloading safer and more convenient. Our standard "Two-Way" skid-resistant surface gives extra traction whether walking up or down the ramp. Our optional "Grate Aluminum" open surface design helps prevent mud, snow or ice from building up on the ramp's surface.

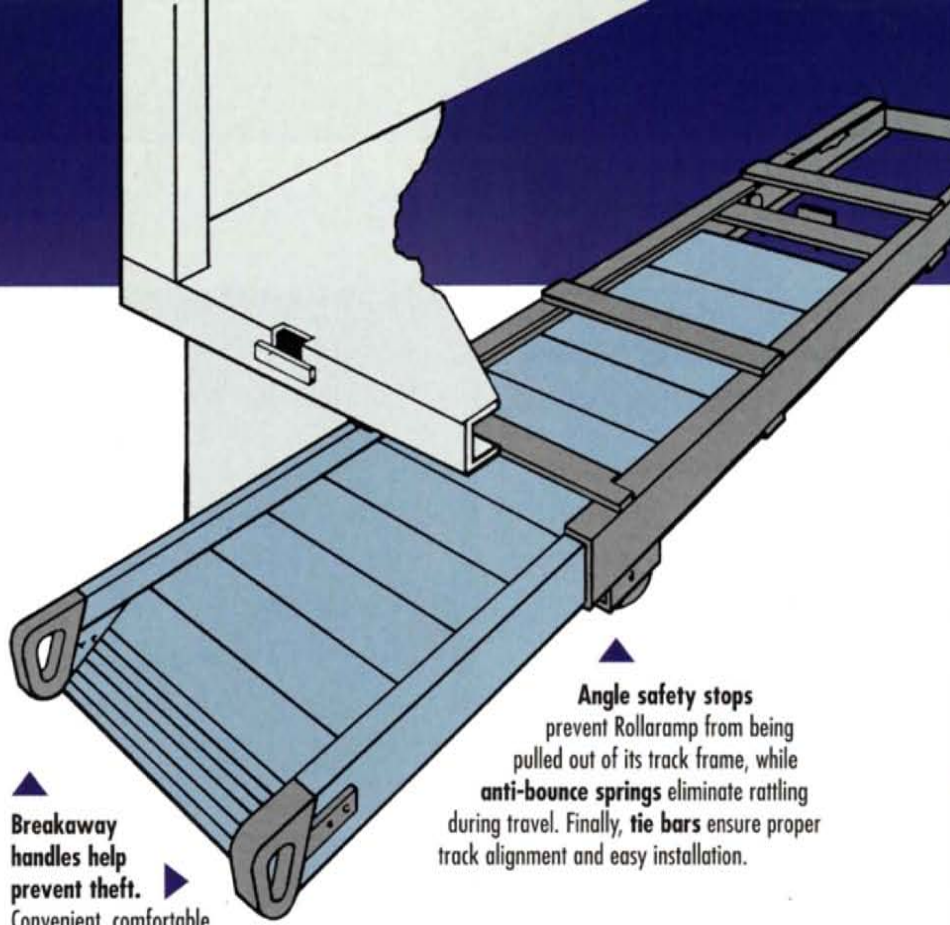

▲ **Breakaway handles help prevent theft.** Convenient, comfortable breakaway handles strong enough to support ramp's weight.

▲ **Angle safety stops** prevent Rollaramp from being pulled out of its track frame, while **anti-bounce springs** eliminate rattling during travel. Finally, **tie bars** ensure proper track alignment and easy installation.

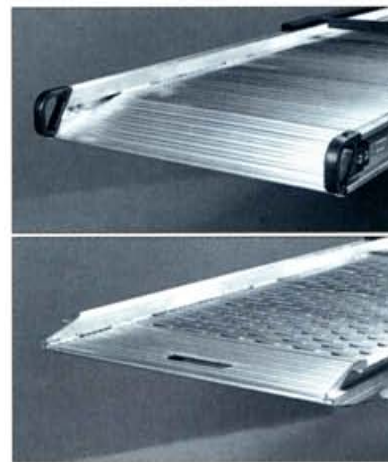

▲ **Select one of two ramp nose designs.** Our standard ramp nose design comes complete with breakaway handles, while our optional horizontal (blunt) nose design (cover photo) has a center handle cut-out.

▲ **Safety latch** keeps Rollaramp securely locked in place.

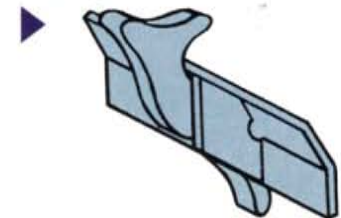

▲ **Cushioned Rollers** for smoother, easier operation.

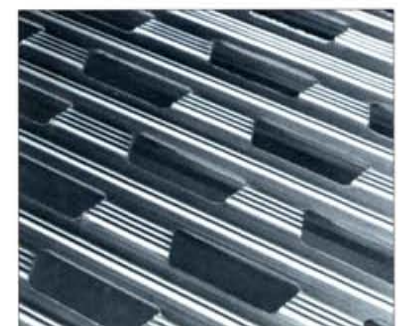
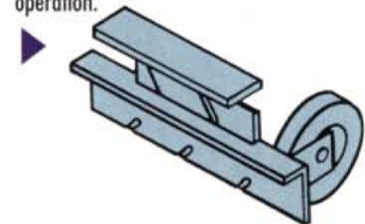



OPTIONS & SPECIFICATIONS

TODCO OVERHEAD DOORS

TRANSPORTATION CORE™

- 3/4" Dryfreight
- 3/4" and 1" Aluminum Skin
- 1" City Delivery
- 1" Long Hauler

EXTRUDED ALUMINUM

- FleetStar™ Double Wall
- CityCargo™
- Compartment Doors

INSULATED FIBERGLASS

- 1-1/8" PolarGuard™
- 2-1/2" PolarGuard

COMPOSITE

- 3/4" WeatherTite™
- 1/2" ArmorPlate™

SWING DOORS

- ArmorTech™

OPTIONAL FEATURES

- Horizontal (blunt) nose design.
- Top- and/or bottom-closed carriers shield ramp from the elements.

MODEL/CAPACITY SPECIFICATIONS

MODEL NO.	SIZE	WEIGHT	CAPACITY	MODEL NO.	SIZE	WEIGHT	CAPACITY
Rollaramp With Frame Assembly				"Grate" Rollaramp With Frame Assembly			
39251-3072	8'	190	2000	39330-3072	8'	170	2000
39251-3840	10'	210	1700	39330-3840	10'	190	1700
39251-4608	12'	230	1500	39330-4608	12'	200	1500
39251-5375	14'	260	1300	39330-5375	14'	220	1300
39251-6144	16'	300	1000	39330-6144	16'	265	1000
Rollaramp Without Frame Assembly				"Grate" Rollaramp Without Frame Assembly			
39252-3072	8'	90	2000	39331-3072	8'	75	2000
39252-3840	10'	110	1700	39331-3840	10'	90	1700
39252-4608	12'	130	1500	39331-4608	12'	100	1500
39252-5375	14'	140	1300	39331-5375	14'	120	1300
39252-6144	16'	150	1000	39331-6144	16'	135	1000
Rollaramp Only				"Grate" Rollaramp Only			
39253-3072	8'	80	2000	39342-0000	8'	65	2000
39253-3840	10'	100	1700	39343-0000	10'	80	1700
39253-4608	12'	115	1500	39344-0000	12'	90	1500
39253-5375	14'	125	1300	39345-0000	14'	110	1300
39253-6144	16'	150	1000	39346-0000	16'	125	1000

SLOPE/GRADE SPECIFICATIONS

MODEL	BED HEIGHT	36"	40"	44"	48"	52"	56"	60"	64"
39251-3072	Degree of Slope	22	25						
	% of Grade	38	42						
39251-3840	Degree of Slope	18	20	22	24				
	% of Grade	31	34	37	40				
39251-4608	Degree of Slope	15	17	19	20	22	24		
	% of Grade	26	29	33	34	37	40		
39251-5375	Degree of Slope	13	14	15	17	18	20	21	23
	% of Grade	23	24	26	29	31	34	36	39
39251-6144	Degree of Slope	12	12	13	15	16	17	18	20
	% of Grade	21	21	23	26	27	29	31	34

Installation Requirements: Rollaramp with frame assembly is 27 1/2"W x 5 3/8"H. Rollaramp only measures 26 1/2" OW, 24 1/2" IW x 3 7/8"H. Installs in new or existing trucks. Existing truck body requires a 30"W x 8 1/2"D opening in vertical rear apron. Installation during body manufacturing requires 30"W x 5 1/2"D. Long sill members should be 6"D to accommodate track. Track assembly requires minimum clearance of 27 5/8" between body hanger U-bolts.

The total assembly length is 24" longer than the ramp length.

For new orders and order inquiries, fax 1-800-24-TODCO (1-800-248-6326). TODCO reserves the right to change product specifications at any time without notice.



1332 Fairground Road East
Marion, Ohio 43302
(740) 383-6376

NOT JUST TOUGH...TODCO-TOUGH.

www.todco.com