

STANDARD PARTS LIST

Item	Part No.	Description
1	50075.1000	Vertical Track Assembly – L.H. (Curbside)
	50075.2000	Vertical Track Assembly – R.H. (Roadside)
2	80352.5180	Hex Nut – 5/16" NC
3	80322.3190	Lock Washer – 5/16"
4	89186.3000	Hex Head Bolt – 5/16" NC X 7/8"
5	51038	Bearing Assembly
6	80300.2414	Hex Head Set Screw – 3/8" NC X 7/8"
7	59129.2000	Cable Drum – R.H. (Roadside) To 105" Door Height
	59157.4000	Cable Drum – R.H. (Roadside) 105" To 120" Door Height
8	51036.2000	Spring Anchor Bracket
9	51043	Spring Anchor Plug – 1-3/4" I.D. Spring
	59024	Spring Anchor Plug – 2-1/2" I.D. Spring
10	51042	Spring – 1-3/4" I.D.
	59031	Spring – 2-1/2" I.D.
11	59158	Spring Winding Plug – 1-3/4" I.D. Spring
	59159	Spring Winding Plug – 2-1/2" I.D. Spring
12	59083	Bearing Assembly – Support Bracket
13	51036.1000	Support Bracket – L.H. (Curbside)
14	59129.1000	Cable Drum – L.H. (Curbside) To 105" Door Height
	59157.3000	Cable Drum – L.H. (Curbside) 105" To 120" Door Height
15	59290	Counterbalance Shaft
16	49702.1000	Horizontal Track – L.H. (Curbside)
	49702.2000	Horizontal Track – R.H. (Roadside)
17	80322.2550	Lock Washer – 1/4" NC
18	80352.4200	Hex Nut – 1/4" NC
19	80105.4140	Hex Head Bolt – 1/4" NC X 1-3/4"
20	69718	Head Seal
21	70288	Retainer – Head Seal
22	70289	Head Seal Assembly
23	29862	Inter. Panel (10") – No Hardware (Specify Length)
	29861	Inter. Panel (11") – No Hardware (Specify Length)
	29859	Inter. Panel (12") – No Hardware (Specify Length)
24	70319	Warning Sticker – Counterbalance
25	61390	Side Seal – Pair

Item	Part No.	Description
26	51044	Cable Assembly – 110" LG. (To 100" Door Height)
	59004	Cable Assembly – 115" LG. (100" To 105" Door Height)
	59003	Cable Assembly – 130" LG. (105" To 120" Door Height)
27	29860	Bottom Panel (12") No Hardware
28	70251	Gasket – Lift Handle
29	61401.0000.05	Lift Handle
30	89299.3000	Pop Rivet – 1/4" DIA. (Grip .063 to .250)
31	70248	Gasket – Keeper Assembly
32	69572.0000.05	Keeper Assembly
33	69571.0000.05	Maximum Security Lock Assembly
34	70093	Catch Box
35	89299.1000	Pop Rivet – 1/4" DIA. (Grip .251 to .375)
36	70247	Gasket – M.S. Lock Back Plate
37	80844.1408	Pull Strap – 30" Straight (Standard) 44" Long
38	70250	Gasket – Pull Strap Retainer
39	69832.0000.05	Pull Strap Retainer
40	89299.2000	Pop Rivet – 1/4" DIA. (Grip .376 to .500)
41	61026	Cable Anchor Pin
42	80401.3160	Cotter Pin – 3/32" Diameter
43	59291.0000.05	Cable Anchor Bracket
44	70352	Gasket – Cable Anchor Bracket
45	89280.1000	Self Drilling Screw #8-18 (Stainless Steel)
46	70354	Bottom Seal
47	70344.1000.05	Bottom Fixture Base – Left Hand
	70344.2000.05	Bottom Fixture Base – Right Hand
48	69793	Nameplate
49	70318	Safety Notice Warning Sticker
50	70309.0000.05	Roller Holder
51	89042.2000	Lock Nut – 1/4" NC
52	61174	Roller
53	80020	Spacer Washer – Roller
54	70308.0000.05	End Hinge Sub-Assembly
	70311.0000.05	End Hinge Assembly (Complete)
55	61196.0000.05	Center Hinge Assembly
56	70351	Joint Seal
57	69432	Base – Adjustable Top Fixture
58	69431	Slide – Adjustable Top Fixture
59	80302.2436	Flat Washer – 3/8"
60	89049	E-Lok Bolt – 3/8" NC
61	59092	Filler Plug – 2-1/2" I.D. Spring

When ordering parts, include part number, description, door serial number and parts list number C-00133

MAINTENANCE GUIDE
Lubricate with TODCO Lube all roller bearings and stems, (lubricate bottom roller stem through holes in bottom fixture), counterbalance bearings, center



and end hinges, and moving lock parts.

Wipe dirt from tracks. Spray horizontal tracks with TODCO Lube or light oil (never grease). Spray counterbalance with TODCO Lube to prevent

rusting. REFER TO SAFETY INSTRUCTIONS STICKER ON DOOR AND OWNER'S MANUAL FOR OPTIONS AND FOR OTHER IMPORTANT SAFETY AND MAINTENANCE ITEMS.



COUNTERBALANCE ASSEMBLIES

Every TODCO counterbalance assembly has been manufactured to meet a custom door specification. TO HELP ENSURE THAT YOU RECEIVE THE CORRECT REPLACEMENT PART OR ASSEMBLY, PLEASE PROVIDE THE DOOR SERIAL NUMBER. This can be found on the metal tag attached to the inside upper right-hand corner of the door.

If the serial number is unavailable, we must have the following information:

- 1) Inside diameter (I.D.) of the torsion spring.
- 2) Length of the torsion spring.
- 3) Number of coils within 10 inches of the torsion spring.
- 4) Length of the shaft.
- 5) Part number on each of the two (2) cable drums.



FLEETSTAR® ACCESSORY PARTS

ORDERING INSTRUCTIONS

When ordering parts, be sure to include the part name and number and your door's SERIAL NUMBER. See metal tag attached to the inside upper right-hand corner of the door (standing inside unit facing the door).



Orders for replacement door panels should specify whether top, intermediate or bottom panel is required (panel width, height and thickness dimensions should be indicated).

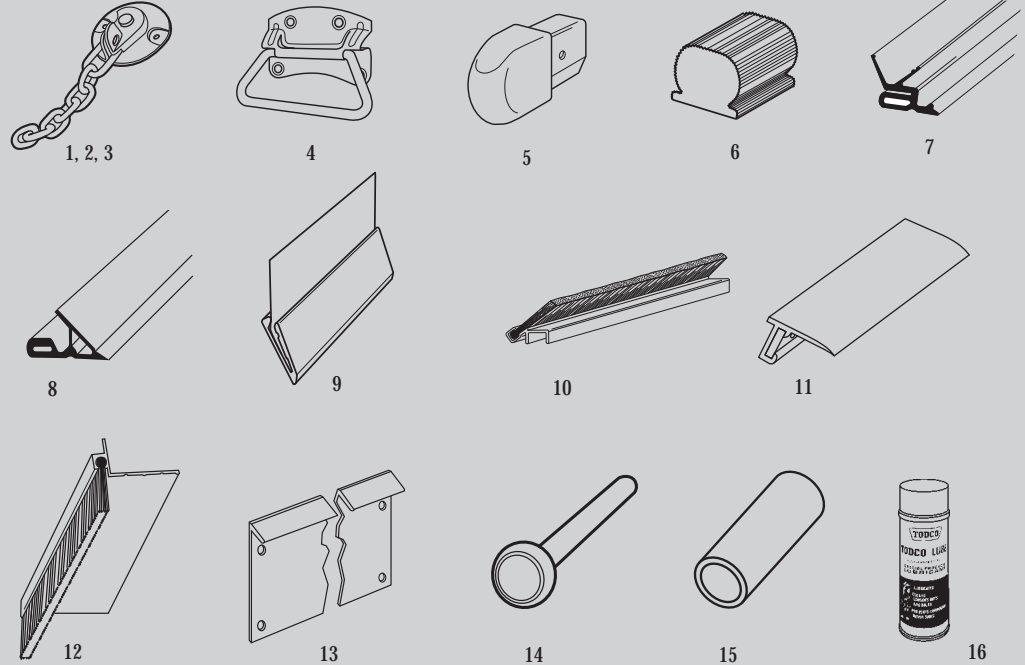

Please order from the TODCO plant nearest you:

Marion, Ohio 43302
1332 Fairground Road East
(740) 383-6376

Fresno, California 93725
4771 East Date Avenue
(559) 485-9830

For new orders and order inquiries, fax 1-800-24-TODCO (800-248-6326).

Item	Part No.	Description
1	61223	Back Plate - Safety Chain
2	61229	Safety Chain
3	69020	Safety Chain Lock Assembly
4	69325	Drop Lift Handle
5	69353	Head Protector (Yellow)
6	61398	Bumper Stop (Black)
7	70131	Side Seal - Dual Lip
8	69840	Side Seal - Extended Lip
9	70105	Side Seal Assembly - Secondary
10	70232	Side Seal Assembly - 1" Brush
	70313	Side Seal Assembly - 1-1/2" Brush
11	69770	Head Seal Assembly (Header Mounted)
12	70278	Head Seal Retainer - 1-1/2" Brush
13	70306-0512	Forklift Plate - Aluminum (16" Long)
	70306-1152	Forklift Plate - Aluminum (36" Long)
14	69162	Roller - 1" Sealed
	70305	Roller - 1" Sealed (Precision Machined)
15	51078	Spring Silencer Boot
16	3900-1012	TODCO Lube (case)

TODCO reserves the right to change product specifications at any time without notice.



NOT JUST TOUGH...TODCO-TOUGH.

www.todco.com